

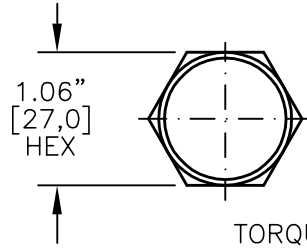

PRIORITY ON DEMAND SPOOL ELEMENT
SPOOL TYPE, FOR LOAD SENSE STEERING.

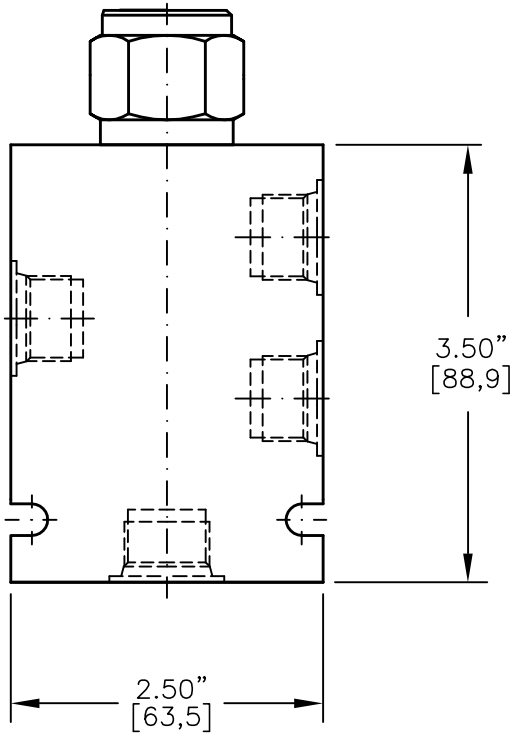

TORQUE to 55/60 Ft-Lb.
[74/81 N-m]

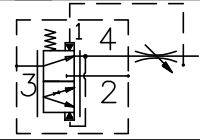
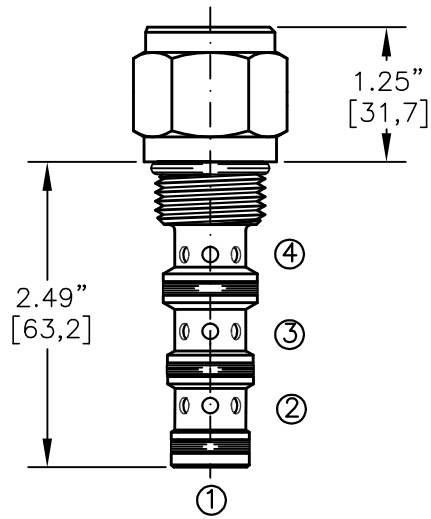

FOR ALUMINUM OR STEEL VALVE HOUSING CONFIGURATIONS SEE PAGE 0-042.1

PODS-10-X-X-X-XXX

BASIC SIZE
10 = 7/8"-14 UNF
SEALS
N = BUNA "N"
V = VITON

ADJUSTMENT
"F" = FIXED ONLY

PRESSURE BIAS SPRING
050 = 50 PSI (FIXED)
100 = 100 PSI (FIXED)
150 = 150 PSI (FIXED)

PORTS
0 = CARTRIDGE ONLY
02BX = G 1/4" BSPP
03BX = G 3/8" BSPP
06TX = SAE - #6
08TX = SAE - #8
"A" - ALUM. HOUSING
"S" - STEEL HOUSING

FOR ADJUSTMENT CONTROL
OPTIONS SEE PAGE 0-050.0

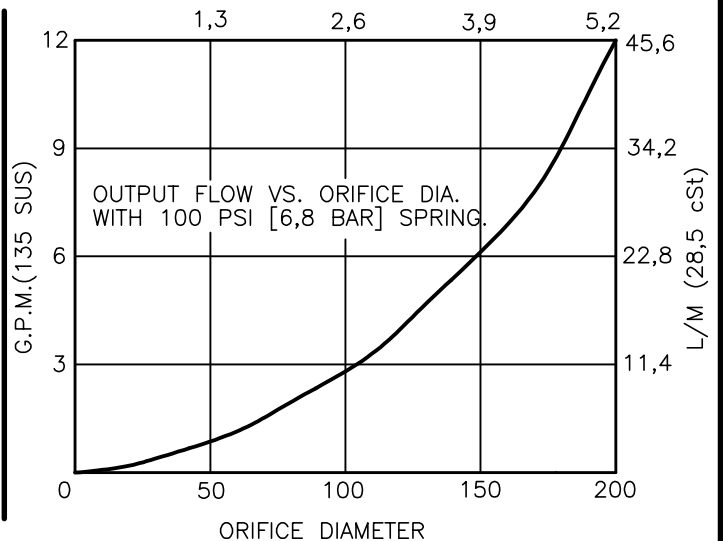



PRIORITY ON DEMAND SPOOL ELEMENT. SPOOL TYPE, FOR LOAD SENSE STEERING.

DESCRIPTION

This unit is a DIRECT ACTING, SCREW IN CARTRIDGE STYLE, SPOOL TYPE, PRIORITY ON DEMAND PRESSURE COMPENSATED FLOW CONTROL ELEMENT. This unit is used to provide a load sense steering first with the priority flow when the steering demands the flow and the amount it requires before any other function in the system. When the steering or any other priority functions are satisfied, only then the excess flow is diverted to the auxiliary port for other functions.

OPERATIONS

When the steering wheel is turned, the flow from port 3 is distributed to the priority port 4 when the system calls for it. The remaining flow is available to the rest of the working hydraulic system thru the excess port 2. The distribution is controlled by the load sense signal to port 1 from the steering unit, so the flow to the steering unit is always determined by the actual steering rate.

FEATURES AND BENEFITS

Hardened precision fitted spool & cage provides reliable, long life. A unibody cage construction provides a very low hysteresis and very reliable operation. All external carbon steel parts are plated for longer life against the elements. All cartridge valves are 100% functionally tested. Industry common cavity.

SPECIFICATIONS

OPERATING PRESSURE: 5,000 PSI [350 Bar]
PROOF PRESSURE: 10,000 PSI [700 Bar]
INLET FLOW: 16.0 GPM [60 L/M]. Regulated see performance chart.
INTERNAL LEAKAGE: 5 cu.in./min. [85 cc/m].
DEFINITION OF CRACK: evident at 0.06 GPM [0.25 L/M]
VALVE HOUSINGS: 2500 PSI [175 Bar] = Aluminum - Anodized.
5000 PSI [350 Bar] = Steel - Unplated.
OPERATING TEMPERATURE: -40° to +250° F. [-40° to +120° C.]
OPERATING MEDIA: All general purpose hydraulic fluids such as MIL-H-5606, SAE-#10, SAE-#20, etc.
INSTALLATION: No restriction.
FILTRATION: 25 microns or better.
SEAL KIT NUMBER: SKN-1040 for buna "N".
SKV-1040 for viton.
WEIGHT: 0.42 lb [.19 kg] cartridge only.
VALVE CAVITY: #C1040, See Page 0-042.0.